

Understanding LEDs



lightcast

briefings from the ILE technical committee



LED lamp

© Olivier Lantzendörffer | Dreamstime.com

16 September 2009

This briefing note has been prepared by the ILE Technical Committee for study and application. The document reports on current knowledge and experience within the specified field of light and lighting described and is intended to be used by the ILE membership and other interested parties. This is a briefing note and is not of mandatory status. The ILE should be consulted regarding possible subsequent amendments.

Any mention of organisations or products does not imply endorsement by the ILE. Whilst every care has been taken in the compilation of any lists, at the time of going to press, these may not be comprehensive.

Compliance with any recommendations does not itself confer immunity from legal obligations.

© 2009 Institution of Lighting Engineers. Permission is granted to reproduce and distribute this document, subject to the restriction that the complete document must be copied, without alteration, addition or deletion.

Contents

1. Introduction	3
2. General	4
3. LED performance	6
4. Luminaire performance	7
5. Driver performance	9
6. Five key questions to ask	10
Appendix	12

1. Introduction

Over the past few years a new light source – light emitting diodes, or LEDs – has been introduced into the exterior lighting market. LED luminaires are now able to deliver appropriate lighting to achieve the lower levels of both the BS5489 ME and the S classes. It is envisaged that within a relatively short period LED luminaires will be available to achieve the requirements of all classes.

The LED luminaires have come from established lantern suppliers who understand the intricate requirements of the UK local authorities, and also from a number of new companies with a background based more on electronics.

This new light source has introduced new terms and uncertainties to the lighting designer/engineers which are making comparisons difficult between competing LED manufacturers and traditional HID lantern performances.

This report does not prescribe a definitive approach but its intent is to assist the lighting fraternity to understand the new technology and to help in a decision-making process when looking for quality products. LEDs promise the benefits of long life, low energy, minimal maintenance and flexible lighting output – this report helps ensure these benefits are realised.

2. General

LEDs were developed in the electronics industry when it was discovered that light is produced when a current is passed through a diode. This technology has seen rapid development in the recent past. A graph of the efficiency of various light sources from 1930 to the present day is shown below.

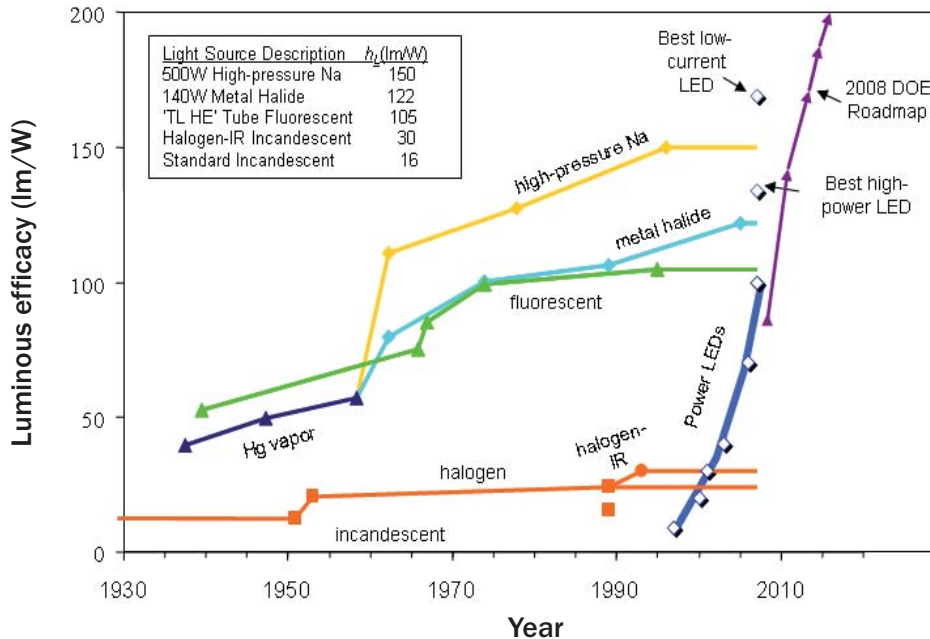

Efficiency in lumens per watt of different light sources from 1930 to the present day

If the trend continues then we may be seeing LEDs capable of producing 170 lumens per watt or more in the short term. This could shortly exceed the performance of all HID lamps and could establish LEDs as the premier light source for efficiency.

However, the intense light produced from a tiny source can be discomforting and can potentially cause disability glare. The LED as a light source is being addressed by European standards regarding laser light.

Therefore if the light output continues to increase, appropriate control of the light will be essential to avoid glare on the highway, or at worst damage to the retina if an individual inadvertently stares at the source for too long.

To achieve white light, either a combination of red, green and blue LEDs is used or a phosphor coating (approximately 21 microns) is applied to a blue LED to convert some of its light output to as many of the remaining visible colours as possible. The resulting 'white' light is, usually, almost all in the visible spectrum with little ultra violet (UV) or infra red (IR) elements. Its colour rendering ability will depend on how closely the spectral distribution matches the human eye. It should be noted that even with a high colour rendering index (CRI 60–90) the visible differences with a conventional white light sources may be considerable due to the way in which CRI is determined. However, if the CRI is above 60, it can be used for subsidiary road lighting to one class lower than if the lamp CRI is less than 60, according to BS5489-1:2003. It should be noted that a white

LED's colour may shift throughout its life because of the effects of both operating temperature and natural ageing.

Currently the most efficient white LEDs are operating at around 5000–6000K, which in northern European climates is often deemed as a cold light. Lantern manufacturers are looking at warming the light through a variety of means to make it more attractive in these climates.

LED failures

Defining a failed lantern is not straightforward compared to an HID source. LEDs should be capable of a very reliable long life if produced from high quality components. However the initial supply of some residential decorative LEDs has shown that the initial light output can drop quickly and the unit can require replacing after a short period.

Light output

The binning (categorising) of the LEDs is a critical point. This affects the relative outputs as well as the colour temperatures.

Most LED manufacturers will provide lumen depreciation curves similar to HID curves for their LED range. This tends to show a lumen depreciation to say 80% or 70% over a period. The graph is often logarithmic-based and is reliant on the LED junction operating temperature and the current driven through the LED. These graphs are projections based on existing knowledge and modelling to predict effective life. Given that these projections tend to lose accuracy the longer the predicted life, claims of significantly more than 60,000 hours need to be supported with manufacturers' data for the specific luminaire.

However, the public lighting engineer is using the LED as a tool to provide a lighting design/ output and it is feasible that a percentage of LEDs in a lantern could fail prematurely. This may leave a high percentage that are still operating, but the lighting distribution may be adversely affected, so although the lighting appears to be fully operational it is performing below the designed level. However, for the lighting engineer, a failure is when the required lighting level falls below the design criteria and thus taking lighting measurements is the only way of ensuring the LEDs are delivering the lighting required, even though this poses practical problems.

LED driver/ballast

The electronic driver can potentially be the most vulnerable part of an LED luminaire and servicing must be a consideration. Whether it is integral, remote or sealed for life depends on the luminaire manufacturers' philosophy and approach to the drivers. However, as with LEDs, it is down to the quality of the design, components and manufacturing. For example, military standard equipment can withstand intense shocks and variations in temperature and provide long life. However the costs are high and a compromise is often delivered. It is the level of compromise that will affect the unit's potential life.

3. LED performance

Manufacturers are continually improving the performance of LEDs. The improved light output from LEDs is not just down to developing the unit itself to squeeze more output from it (although there is an element of that); the enhanced performance often occurs in incremental steps where a new approach has been found to make substantial improvements (for example, removing the skin for the LED junction from its back which lets more light out.)

Therefore this report does not identify particular values that should be achieved now as they may become meaningless as development moves forward.

This report identifies key aspects of LED performance which the manufacturer should supply and the buyer should ask to have demonstrated or identified in the technical literature.

The LED manufacturer should provide data on the optimum operating conditions for each LED with a window that will allow variation of operation.

The LED operating temperature is critical to light output and lifetime; the junction and board temperature should be at as low a temperature as possible to prolong life.

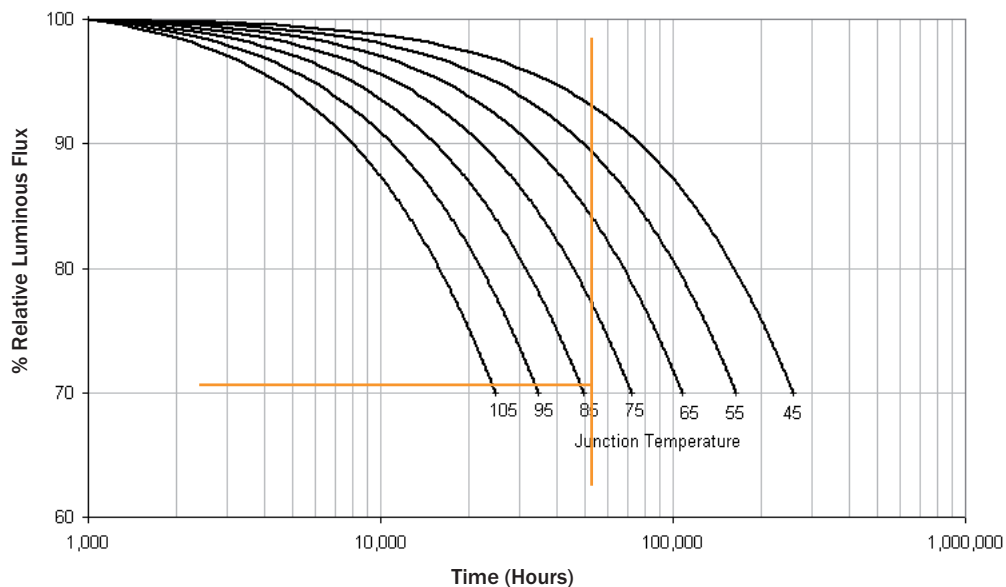

Typical life of LED with differing junction temperatures (degrees centigrade) over time (hours)

The light emitted by LEDs is fundamentally within the visible spectrum with negligible amounts within the UV or IR range. Therefore LEDs have a lower environmental impact than other light sources, particularly those that have a UV content as this tends to attract flying insects that then attract bats.

The LED drive current is provided by the LED driver (see section 5, Driver performance) and this will drive a known current through the LED. Working to the manufacturers'

preferred optimum values will see the LED provide the lumen output with given life. However, as LEDs are solid state units they are capable of being both under-run – i.e. the current is reduced, reducing the light output and extending its life, or they can be overrun, which will increase the light output but reduce the LED life.

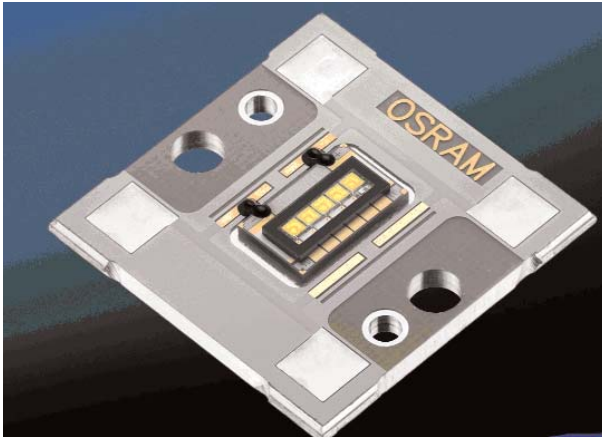

Typical mounted LED chip

4. Luminaire performance

The luminaire needs to enable the lighting engineer to provide the required lighting levels and standards efficiently. The luminaire also needs to control the light from the LEDs and deliver it in an efficient manner without causing glare or light trespass.

However some LED fittings tend to cut light off very sharply which may not be good for residential areas and gives very poor vertical or semi-cylindrical illuminance – see BS5489: Part 3:1992 Section 3.2 paragraph 2. This aspect of lighting is still important, despite the fact that it is no longer mentioned in the current ILE standard. The k-curves will tell the designer what he needs to know about wasted light.

LED luminaires are available with either direct or indirect lighting projection. Within these two types are too many variations to comment on in detail, but the broad advantages and disadvantages of either system are listed below.

Direct advantages	Direct disadvantages
More accurate optical control	Difficult to control glare
Greater efficiency possible with some designs	Potentially poor uniformity
Flexibility of design	Failure conditions very noticeable
	Often large luminaire footprint
Indirect advantages	Indirect disadvantages
Better glare control	Optical control dependent on reflectors
Better uniformity	Slightly lower system efficiency
Compact design possible	

Lumen depreciation and maintenance factors

The UK lighting industry has agreed to quote L80 as the normal depreciation figure to be used on all LED luminaires.

With HID lamps and their established lumen depreciation and life graphs, combined with the luminaire's maintenance factor (MF), an overall MF that can be used in lighting calculations can be obtained. With a 3–5 year life for HID lamps it is acceptable methodology to over-light the subject for a number of years before changing the lamp to ensure the design levels are constantly being achieved. As LED luminaires are likely to have a substantially longer life than HID lamps this traditional approach may not be appropriate, and particularly with the focus on energy reduction, over-lighting for 25 years may seem excessive.

Constant output drivers providing a constant light output are available that will manage the light output throughout the luminaire's life. An MF approaching 100% could therefore be considered.

Alternatively, lighting designers will need to make some engineering judgement to provide a practicable solution.

Photometry from the lantern manufacturers may vary as a unified approach to measurements has yet to be agreed.

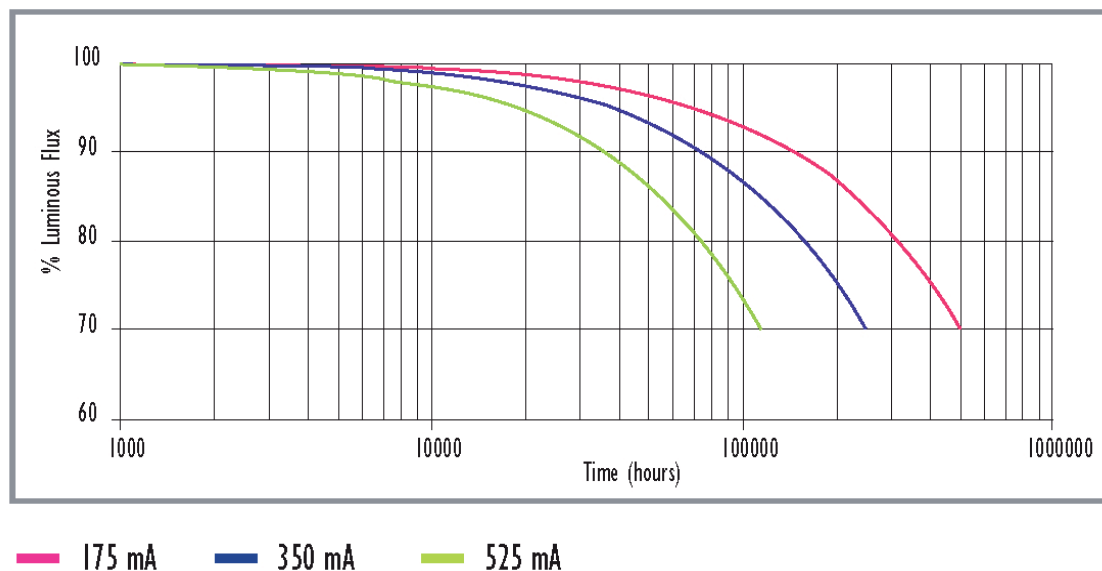

Graph showing typical lumen depreciation with drive current and time

5. Driver performance

LED drivers perform a similar function to the electronic ballasts used with HID lamps, and many of the same criteria apply.

General

There are many LED drivers available on the market – constant current, constant voltage, DALI addressable, 0–10v dimmable and even drivers that can dim LEDs using a domestic dimming potentiometer – so the correct type should be chosen for the given application. LEDs are often chosen and used on their merits of efficiency, but the efficiency of the driver is often overlooked, and this is where efficiency can be lost. Some drivers have an efficiency as low as 50%. A high efficiency design ensures cool operation and longer service life.

Operating temperature

If an LED driver is used within its temperature and voltage rating, unreliability should not be a problem. As with any electronic component, reduced running temperature should ensure increased expected lifetime of a driver. A reduction in temperature of 10 degrees, according to Arrhenius' law, may double the lifetime of a driver. Drivers will normally be marked with a maximum case temperature, T_c , which should not be exceeded when the lantern is subjected to the maximum ambient temperature specified by the lantern manufacture standard. For most of the driver's lifetime, its temperature will be well below this value.

Constant output

The LED's light output is determined by the applied current. LEDs need to be driven at constant current as the LED light output and power consumption varies less with small changes in current than for small changes in voltage. A constant voltage will, even within the same LED type, result in significantly different light output. Hence an LED driver system consists of two stages: a power supply, converting the alternating mains current to a direct current, and a current control unit, providing a constant current.

LED drivers are available that will self-monitor the LEDs and be able to drive the light output consistently through its lifetime, avoiding the lumen depreciation through the LED life.

Placement

Usually, the LED driver should be placed close to the LEDs where possible in order to reduce electromagnetic interference. Adequate heat management should be used to ensure that both the driver and the LEDs run as close as possible to their optimum temperatures.

Failure

The life of drivers is determined by the life of each individual component, the power and temperature. The LED driver should be chosen to have a lifetime compatible with that of the LEDs. As with any similar component, the quality of the components is important to the life of the driver. Each component has its own rated life and this should be taken into consideration. Often the limiting components are electrolytic capacitors, which become dry during their lifetime. Since they dry even without being operated at high temperatures during daytime, even though they may be running at well below T_c for much of their life, the prediction of a lifetime in service is extremely difficult.

The typical quoted lifetime of a driver is often taken as the point where 10% of the LEDs have failed. It may be that the life of the driver is appreciably less than the expected lifetime of the LEDs, requiring replacement within the LED's life. Hence drivers should be easily accessible.

6. Five key questions to ask –

Factors influencing the suitability of an LED luminaire for outdoor use

Q1 Average life expectancy of the LED

Q1a *What is the hot and cold junction or board temperature of the LED?*

The temperature will have a direct bearing on the life of the LED. The cooler the board/junction temperature the longer life the product will most probably have. The supplier should advise what the temperature is when tested in the lab (cold) and also when tested live (hot). It is usual for laboratories to test LEDs at an ambient temperature of 25°C. There are moves to drop this to 15°C for street lighting lanterns to better reflect the working temperatures of lanterns in northern Europe.

Q1b *What forward current are the LEDs being driven?*

The life expectancy is usually given as the life to give a certain percentage of the flux compared to a new LED, L_{80} – the life to 80% flux – being typical. Long quoted life may be simply the life to a lower flux output (e.g. L_{50}). A standard test method for the measurement of lumen maintenance of LEDs is IESNA LM80 and is commonly used by the major LED manufacturers. Fixture manufacturers should be able to substantiate lifetime claims through determining the LED 'junction temperature' at the highest design ambient temperature that the fixture is suitable for. The operating current for the LED relating to its operating temperature will provide information on the light output and projected life.

Q2 What test conditions are the photometry based on?

The output of LEDs is dependent on temperature and therefore it is important to know the conditions on which the output is based. Unrealistically low test temperatures in the laboratory will yield a higher output than is achievable in practice and the fixture may therefore not deliver what is expected.

Q3 Average life expectancy of installed driver

The driver life should be rated and tested in a similar manner to HID ballasts. The life of a driver may have an impact on the life of the lantern, i.e. it may be the part with the shortest life. As a general rule the cooler the driver and its components are running the longer and more trouble free it is likely to be.

Q4 Total circuit/system watts

It is important to understand real electrical load and whether the lantern has an UMSUG rating.

Q5 Colour appearance and rendering

Q5a What colour temperatures are the LEDs working at?

The most current efficient LEDs are cooler in appearance (5000–6000K) but may not be perceived as warm enough in the UK and other northern European countries.

Q5b Do they maintain a stable colour over the entire rated lifetime? How do you know?

Colour stability is a common problem in lower quality LED fixtures. It can be a result of poor LED selection, poor thermal management, or both. LEDs should be appropriate for the application (lighting-class LEDs, not 5mm lamps designed for toys and novelties, for example), and the lantern design should have a good thermal management capacity for the worst-case expected operating environment. Colour shift is measured through Macadam Ellipses and the fewer steps the LED is rated at (for example, 2 Macadam Ellipses) the less variation is likely through life.

Panel

Nigel Parry – ILE

Nigel Townsend – Urbis Lighting

Car Clarke – Advanced LEDs

Steve Austin – Philips Lighting

With supporting information from numerous ILE members

Appendix

Guidelines for specification of LED lighting products

Cross industry agreed guidance to enable the specification of the appropriate LED lighting product is reproduced below.

Guidelines for Specification of LED Lighting Products

With LEDs emerging as a new light source there is a need to ensure performance claims are made in a consistent way. Although standards are developing there was concern that the speed of innovation was moving ahead of standardisation. As a result a number of organisations have produced a template as the basis for the specification of LED luminaire performance criteria.

Criteria

These criteria are designed to ensure that performance claims can be matched against traceable data. They are also designed to ensure that the performance data relates to the luminaire during operation and not just to the performance of the LED. This is because:

- **Thermal Losses:** The temperature of the p-n junction of the raw LED (die) (T_j) is measured at an ambient temperature in the vicinity of the LED of 25C whereas in a luminaire it will be operating at a higher temperature. All performance parameters are variable with Junction Temperature (T_j).
- **Optical Losses:** In addition the luminaire often includes 'secondary' optics to suit the particular application needs of such luminaire, but leading to additional performance losses as well.
- **Driver Electronic Losses:** In most cases an 'LED-driver' is included in the luminaire which will introduce additional losses compared with the initial LED performance.

Data

Data is split into two parts:

1. Luminaire manufacturers design data, available for traceability
2. Luminaire manufacturers declared performance data

Measurement

Five CIE technical committees are currently working on measurement methods for the measurement of LED performance. (See Annex B).

For luminaire designers the LEDs are normally supplied as a package comprising of the silicon wafer integrated into a package ready for placing onto a circuit board or within a luminaire. There is an advised operating temperature, to achieve their design performance, on the outer surface of the package or LED module T_{board} (see figure 1) This may be achieved under normal operating conditions and also at the rated voltage/current/power when appropriate measures to remove heat from the device have been adopted. The junction temperature can be calculated from the thermal resistance/W data available from the LED supplier.

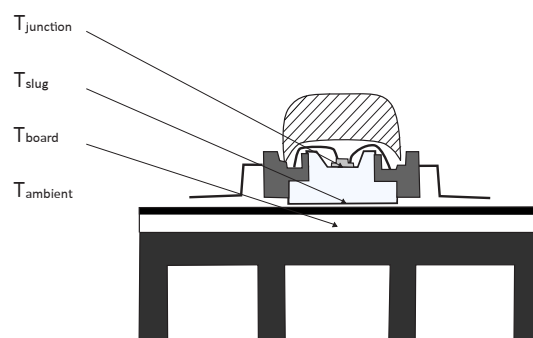

Figure 1: Critical temperature points in a High Power LED

1. Luminaire manufacturer's design data, available for traceability

- 1.1 Manufacturer of the LED package and part number or other device identifier
- 1.2 Drive current/voltage/power
- 1.3 Lumen depreciation curves, electrical life, CCT, x & y and CRI for the LED package outside the luminaire at an ambient temperature of 25°C
- 1.4 The board temperature T_{board} ** of the LED package installed in the luminaire, when the luminaire is operating at an ambient temperature of 25°C. (15°C for Exterior luminaires)
- 1.5 Lumen depreciation curves, electrical life, CCT, x & y and CRI for the LED package at the operating T_{board} **
- 1.6 The colour bin, CCT, x & y, values and MacAdam ellipse category (e.g. Cat 1-4) of the LED package at the operating T_{board} **
- 1.7 Ra8 Colour Rendering Index at the operating T_{board} **
- 1.8 Ra14 Colour Rendering Index at the operating T_{board} **

** These may be calculated from the LED manufacturers data of performance vs junction temperature, taking account of the thermal resistance between the junction and the board, assuming accurate correction curves exist.

2. Luminaire manufacturer's performance measurement

- 2.1 Luminaire lumen output
- 2.2 Luminaire power
- 2.3 Luminaire efficacy
- 2.4 Correlated Colour Temperature, CCT (+ shift over life)
- 2.5 Colour coordinates, x & y (+shift over time)

- 2.6 Colour rendering index, CRI, Ra8 (+ shift over life)
- 2.7 Luminaire Life which should always be qualified by:
Lumen depreciation / maintenance at L80
Failures over life at F10
- 2.8 Luminous Intensity Distribution

Luminaire manufacturers' performance claims are measured in accordance with the requirements of IEC/PAS 62612: Edition 1: 2009-06: Clauses 4,6,7,8,9,10 and 11. (The testing quantity for LED Package lamps is given as minimum 20 and a value for modules and luminaires will need to be checked.)

The drive current and bin reference for the LED used for luminaire performance data should be stated.

Supporting information on the performance claims is given in Annex A

3. Photometry

Photometric data is available in two formats. Absolute Photometry does not require the use of a separate lumen output for the light source. Relative Photometry requires the LED package flux to be quoted. Both methods produce the same result. The manufacturer should state the format in which the photometric data is supplied.

Absolute photometry of LED luminaires should be conducted according to IES LM-79-08 Photometric Measurements of Solid-State Lighting Products. Relative photometry should be conducted according to EN13032-1 (2004) Light and lighting - Measurement and presentation of photometric data of lamps and luminaires - Part 1: Measurement and file format file format.

These standards contain advice on measurement uncertainty. Luminaire performance data to be quoted at operating temperature T_{board} .

Photometric results that are calculated by deviation from the tested sample by the use, for example, of higher or lower drive currents or dies from bins other than the bin used for the tested device are to be clearly identified as such. Correction factors used are to be provided with the results.

Annex A and B

A1. Efficacy

Luminaire efficacy should be calculated from the initial lumen output of the luminaire that has reached thermal stability operating in an ambient temperature of 25°C and based on the total power of the LEDs and driver circuit.

A2. Colour Point (see Clause 7 IEC 62612/PAS)

The colour point (x & y) of the luminaire and the colour temperature derived from it shall be one of the listed preferred values.

Tolerance (categories) on nominal x & y values

All measured x & y colour coordinates:

3-step ellipses Cat 1

5-step ellipses Cat 2

7-step ellipses Cat 3

A3. Life (see Clause 10 IEC 62612/PAS)

Life is calculated based on two factors: lumen depreciation and failure. Life testing also consists of an endurance test. It should be made clear what part of the life and lumen depreciation has been measured and what has been derived from extrapolation or calculation.

A4. Lumen Depreciation

The length of time during which a complete LED luminaire provides more than a percentage of the rated luminous flux under standard test conditions. A customer must be assured that the declared life is the design life. It should be made clear which figures have been measured and which have been derived from extrapolation or calculation.

For illuminating luminaires the percentage should be >80%, indicated as L80. For direct view luminaires the percentage should be >50%, indicated as L50

A5. Failure

The percentage of a number of tested LED's of the same type, that have reached the end of their individual lives and have no visible light output.

For luminaires the percentage should be <10%, indicated as F10

A6. Endurance test

This consists of the following:

- Temperature cycle shock test
- Voltage switching test
- Ambient temperature test at 45°C

It should be made clear which figures have been measured and which have been derived from extrapolation or calculation

A7. Temperature cycle shock test

Luminaire to be operated at full power (at elevated ambient temperature; in excess of 45°C) until Tboard = LED manufacturers maximum operating limit for 1 hour then luminaire to be rapidly cooled to 0°C by placing in a temperature controlled container set to 0°C until Tboard = 0°C.

A8. Voltage switching test

Luminaire to be subjected to a switching cycle of 5 seconds on 5 seconds off for 2 minutes.

A9. Ambient temperature test at 45°C

Luminaire to be operated in a temperature controlled container set to 45° C. Tboard to be monitored until steady state reached. If Tboard exceeds LED manufacturer's value for claimed life and output of fitting then test is failed.

B. CIE Technical Committies

- TC2-46 CIE/ISO standards on LED intensity measurements
- TC2-50 Measurement of the optical properties of LED clusters and arrays
- TC2-58 Measurement of LED radiance and luminance
- TC2-63 Optical measurement of High-Power LEDs
- TC2-64 High speed testing methods for LEDs

This document is approved for use by the following:



lightcast

briefings from the ILE technical committee

Institution of Lighting Engineers

Regent House
Regent Place
Rugby
CV21 2PN

